

CAPITOLATO TECNICO PER CAMERA ULTRA ALTO VUOTO

Oggetto della fornitura: camera da ultra alto vuoto per spettrometro Compton

Specifiche tecniche:

- La camera da ultra alto vuoto che conterrà lo spettrometro Compton deve essere realizzata in acciaio AISI304
- dimensioni come da disegni tecnici in allegato ELI_NP-COM- 000 / 003
- Prima della spedizione il fornitore dovrà eseguire un set di misure di verifica delle tolleranze sulle dimensioni della camera e posizionamento dei supporti meccanici
- Alla fine della lavorazione dovrà essere effettuata una pulitura che la renda adatta ad applicazione di ultra alto vuoto
- La camera deve essere completa delle flange di chiusura come da disegni allegati ELI_NP-COM-004 / 005

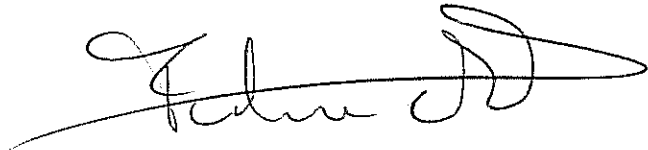

A handwritten signature in black ink, appearing to be 'Federico', written in a cursive style.

All dimension in:
 mm cm m in ft

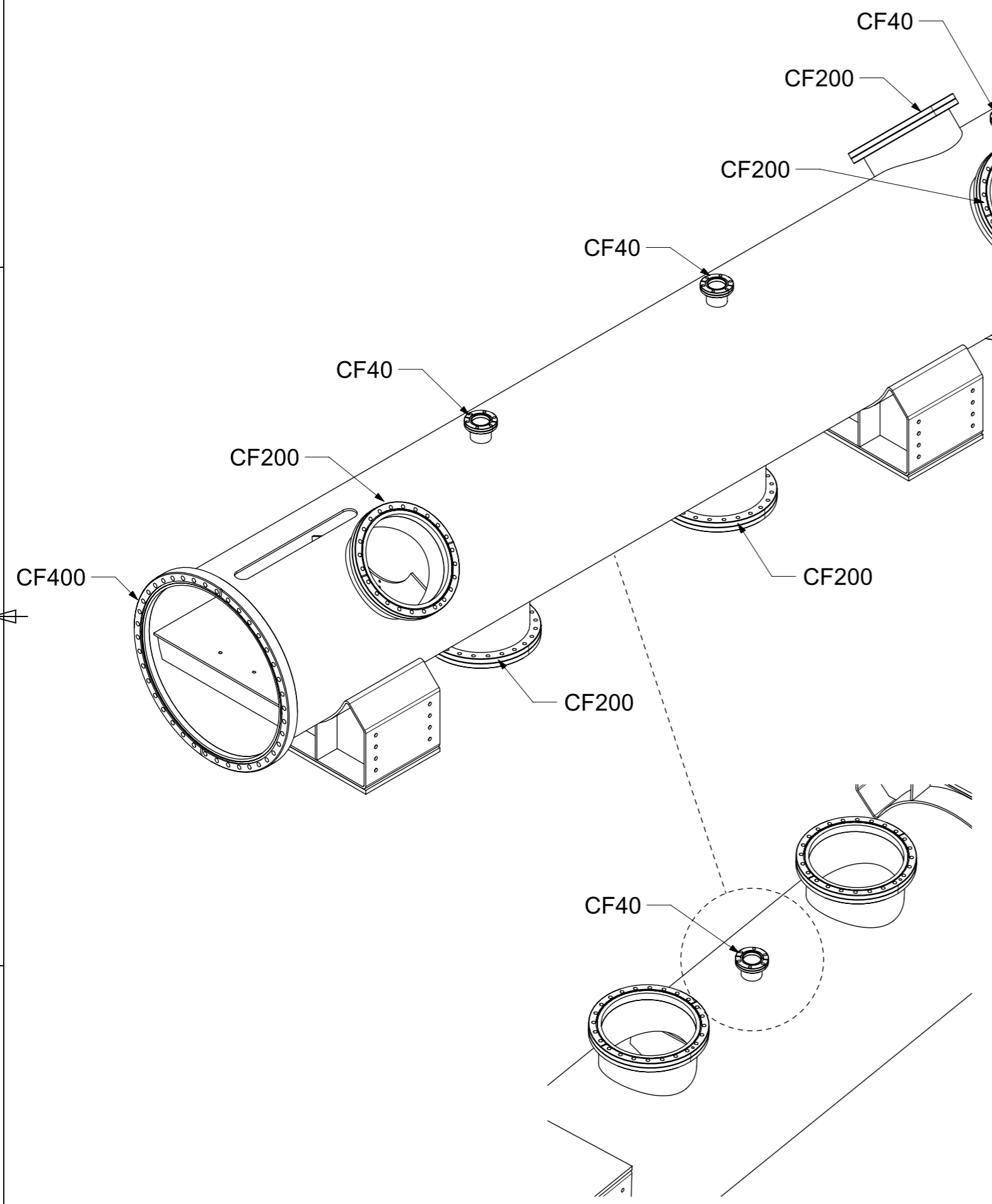
Rev.N	Revision note	Date	Signature



NOTE:
 - TUTTE LE FLANGE HANNO FORI PASSANTI NON FILETTATI

		AISI304	CAMERA COMPTON	1
PART N.	DRAWING	MATERIAL	DENOMINATION	Q.TY
Gen. Tol. for untoleranced dimension: ISO 2768-mk-E		Geometrical tolerance: ISO 8015 - E		Roughness: ISO 1302
 Istituto Nazionale di Fisica Nucleare Sezione di Ferrara		Designer FEDERICO EVANGELISTI	c/o Polo Tecnico-Scientifico Blocco C - Studio 114 Via Saragat 1 - 44122 Ferrara Tel 0532974296 e-mail: evangelisti@fe.infn.it	
		Approved FEDERICO EVANGELISTI		
ELI_NP		Experiment/Project	Scale	Date
COMPTON			A3	03/12/2015
				Document no. ELI_NP-COM-000
				File name ELI_NP-COM-000.pdf

All dimension in:
mm [] cm [] m [] in [] ft []

Rev.N	Revision note	Date	Signature
10			

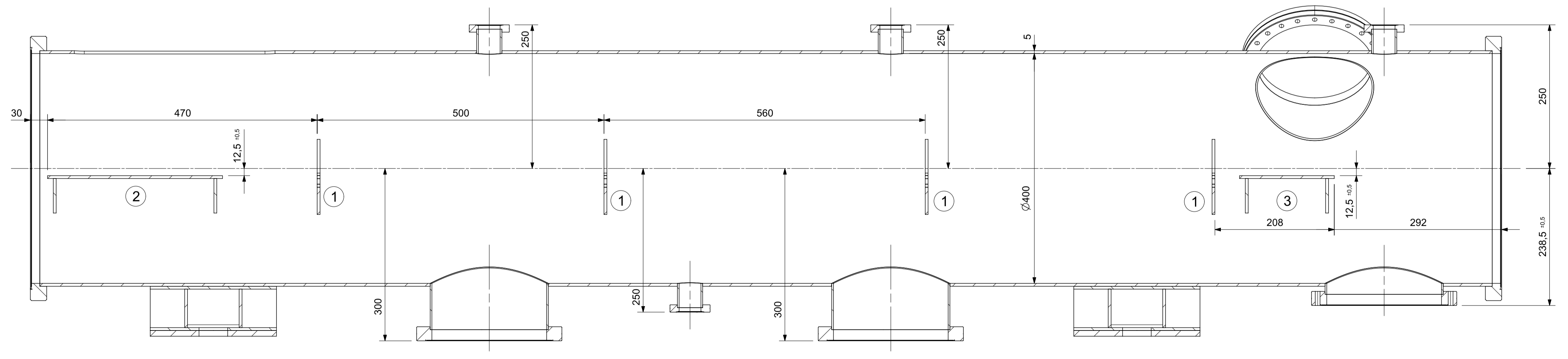
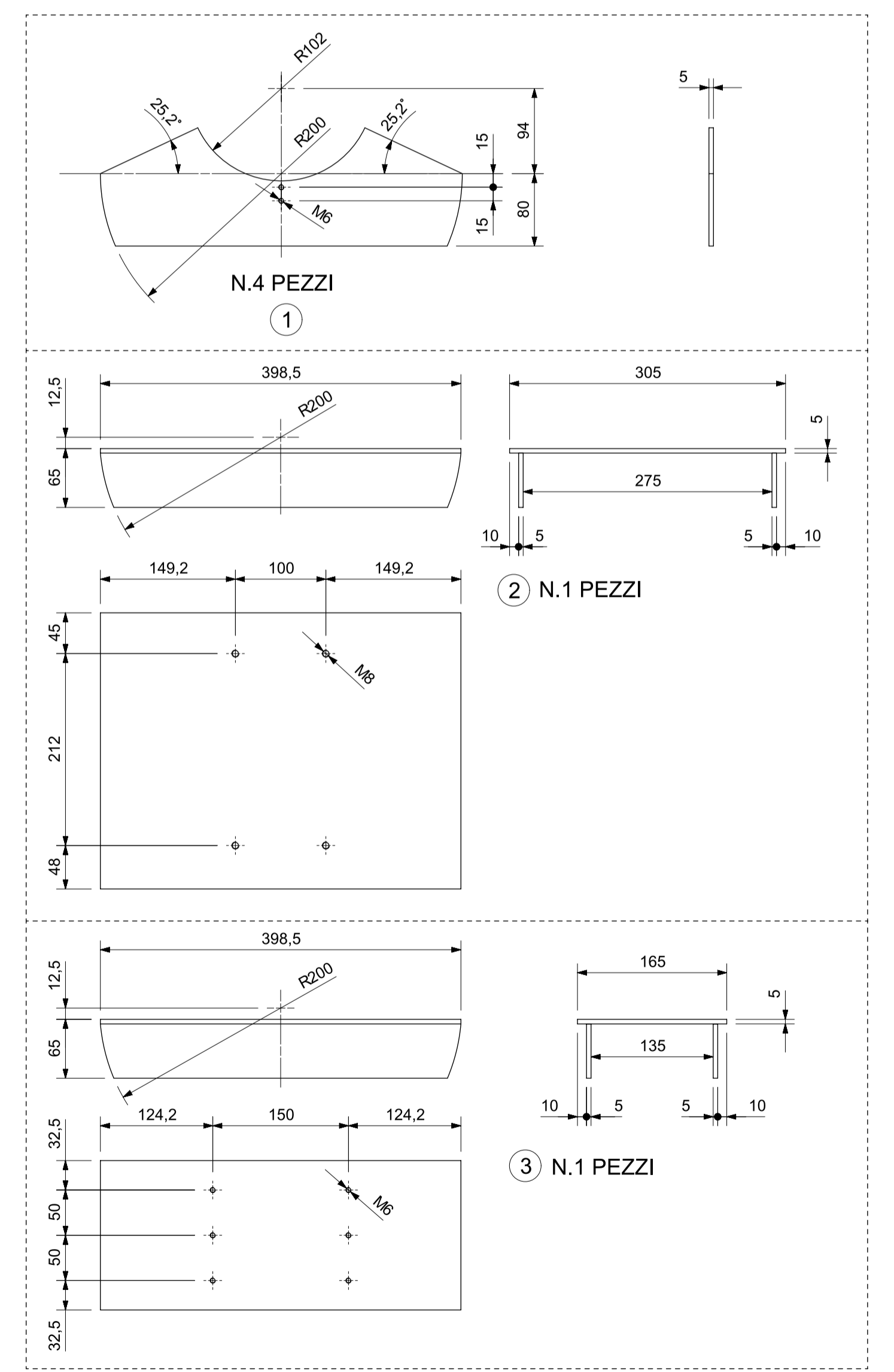
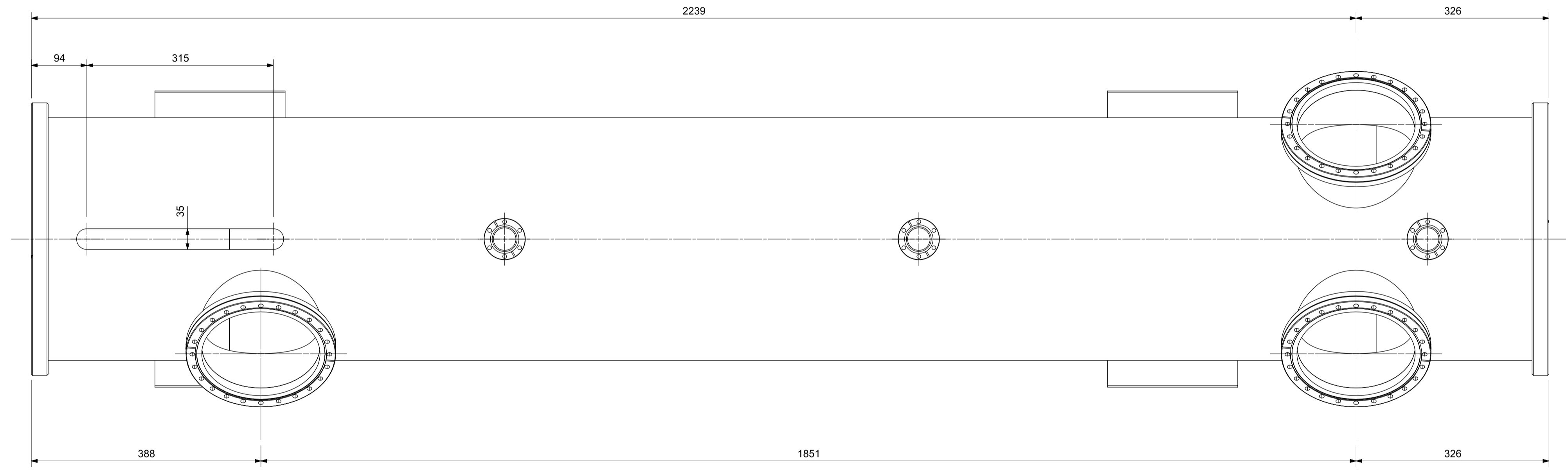
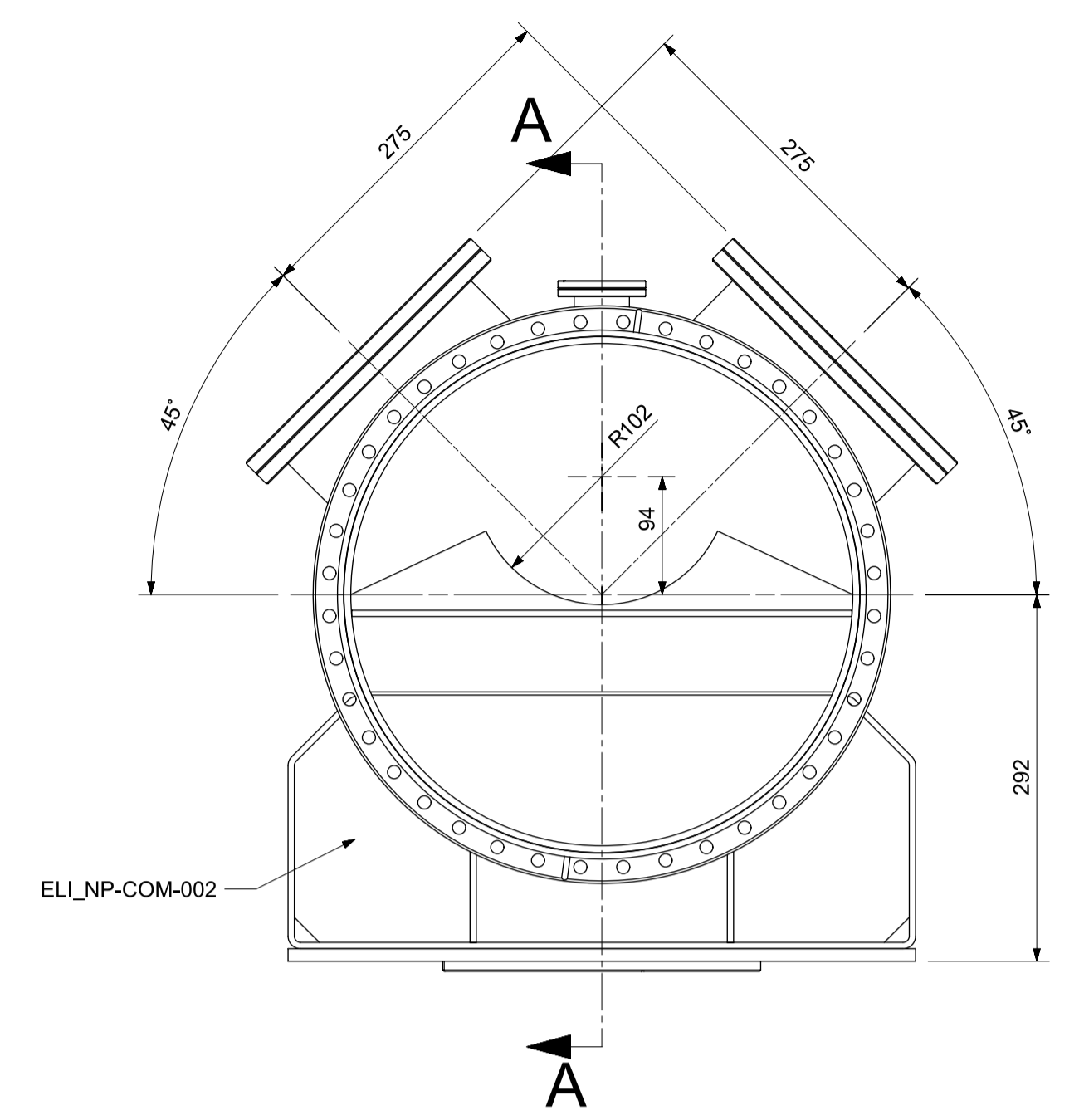
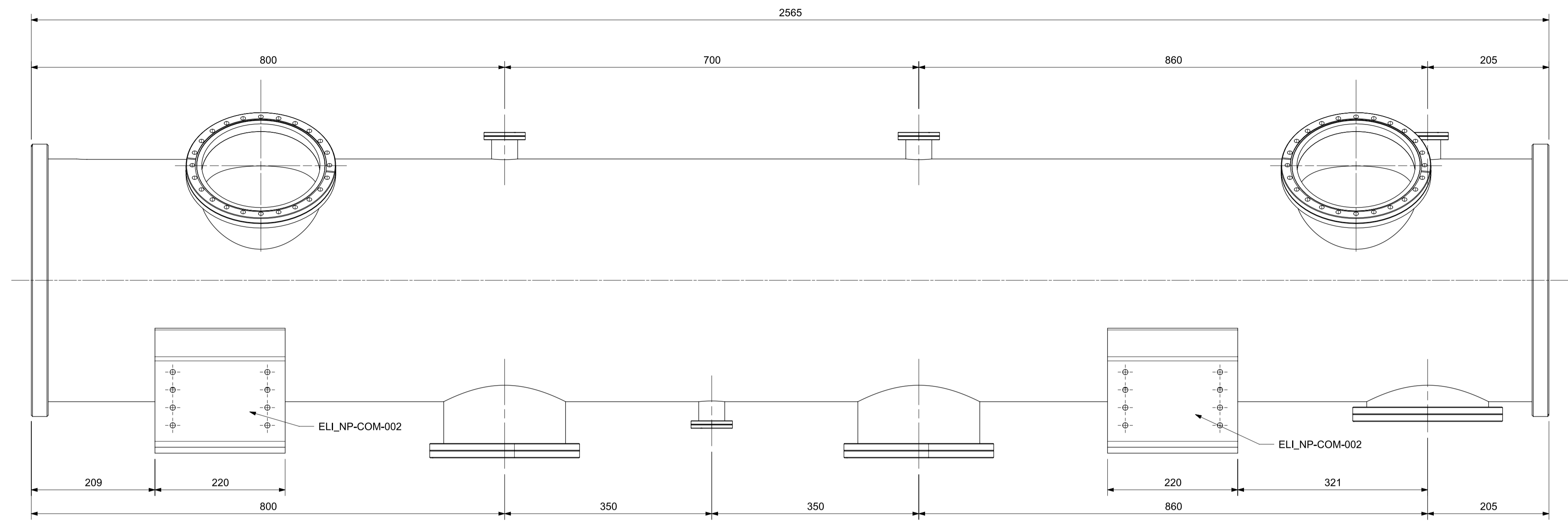

SECTION A-A

NOTE:
- IMPORTANTISSIMO ORIENTAMENTO FORI FLANGE

PART N.	DRAWING	AISI304	CAMERA COMPTON	1
Gen. Tol. for untolerance dimension: ISO 2768-mk-E	Geometrical tolerance: ISO 8015 - E	Roughness: ISO 1302		
Istituto Nazionale di Fisica Nucleare Sezione di Ferrara		Designer: FEDERICO EVANGELISTI Approver: FEDERICO EVANGELISTI	c/o Polo Tecnico-Scientifico Blocco C - Studio 114 Via Saragani 1 - 44122 Ferrara Tel. 0532974296 e-mail: evangelisti@inf.it	
ELI_NP	COMPTON	Scale: 1:5	Date: 03/12/2015	Document no: ELL_NP-COM-001
		Size: A1	Sheet: 1	File name: ELL_NP-COM-001.pdf

All dimension in:
 mm cm m in ft

Rev.N	Revision note	Date	Signature

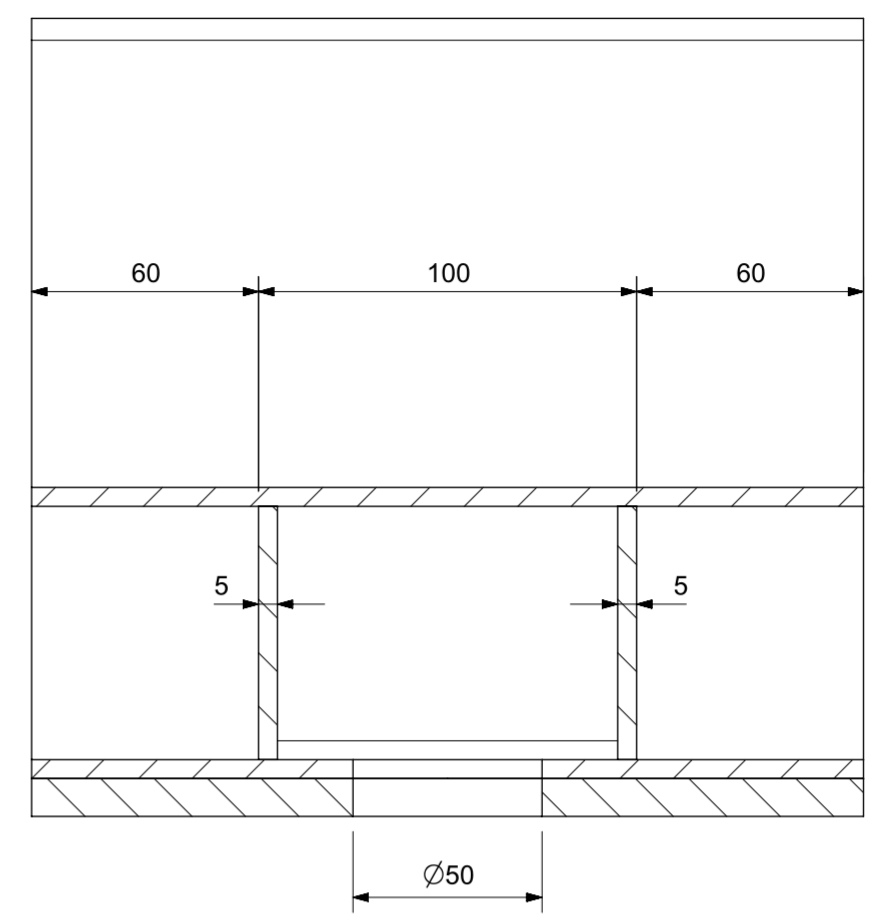
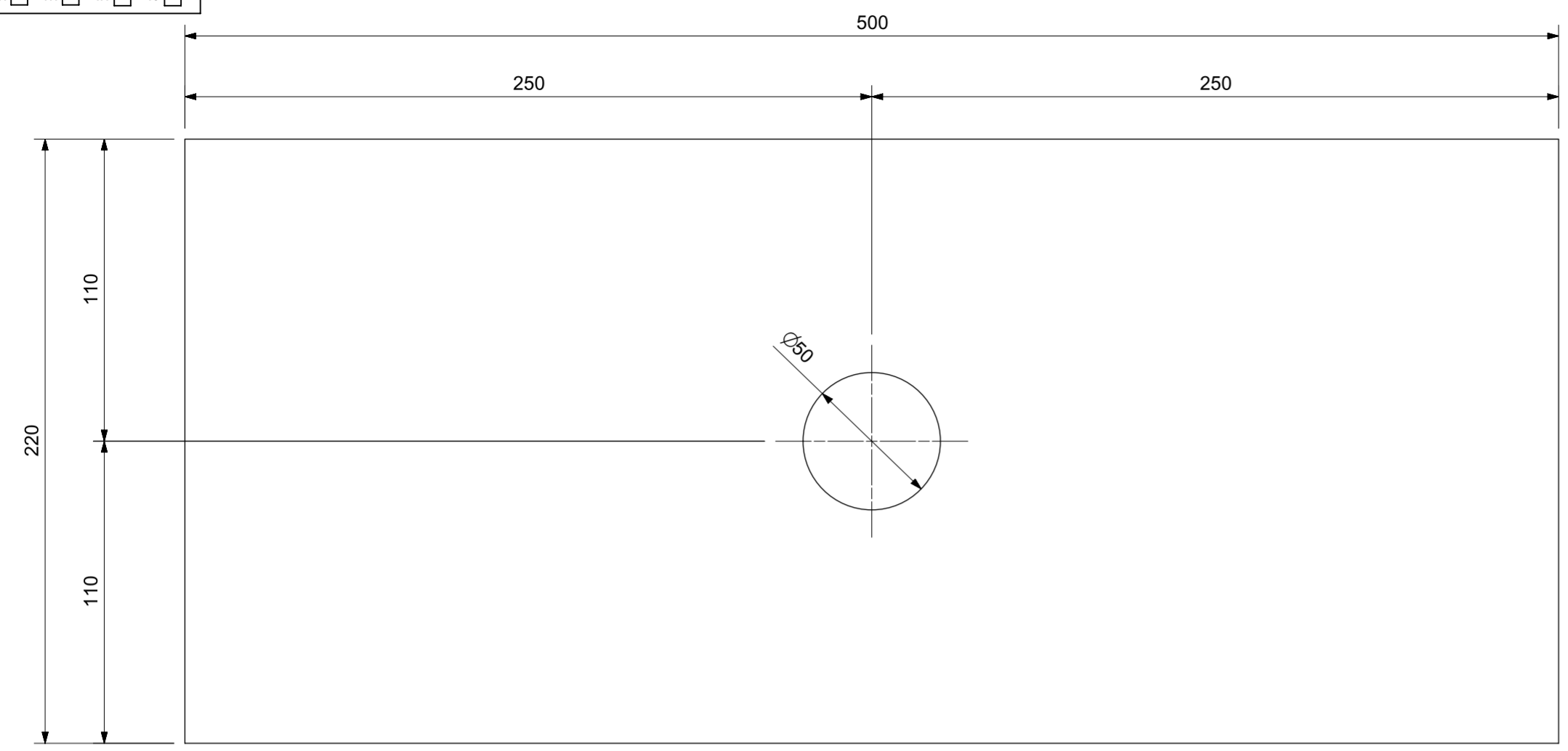

SECTION A-A

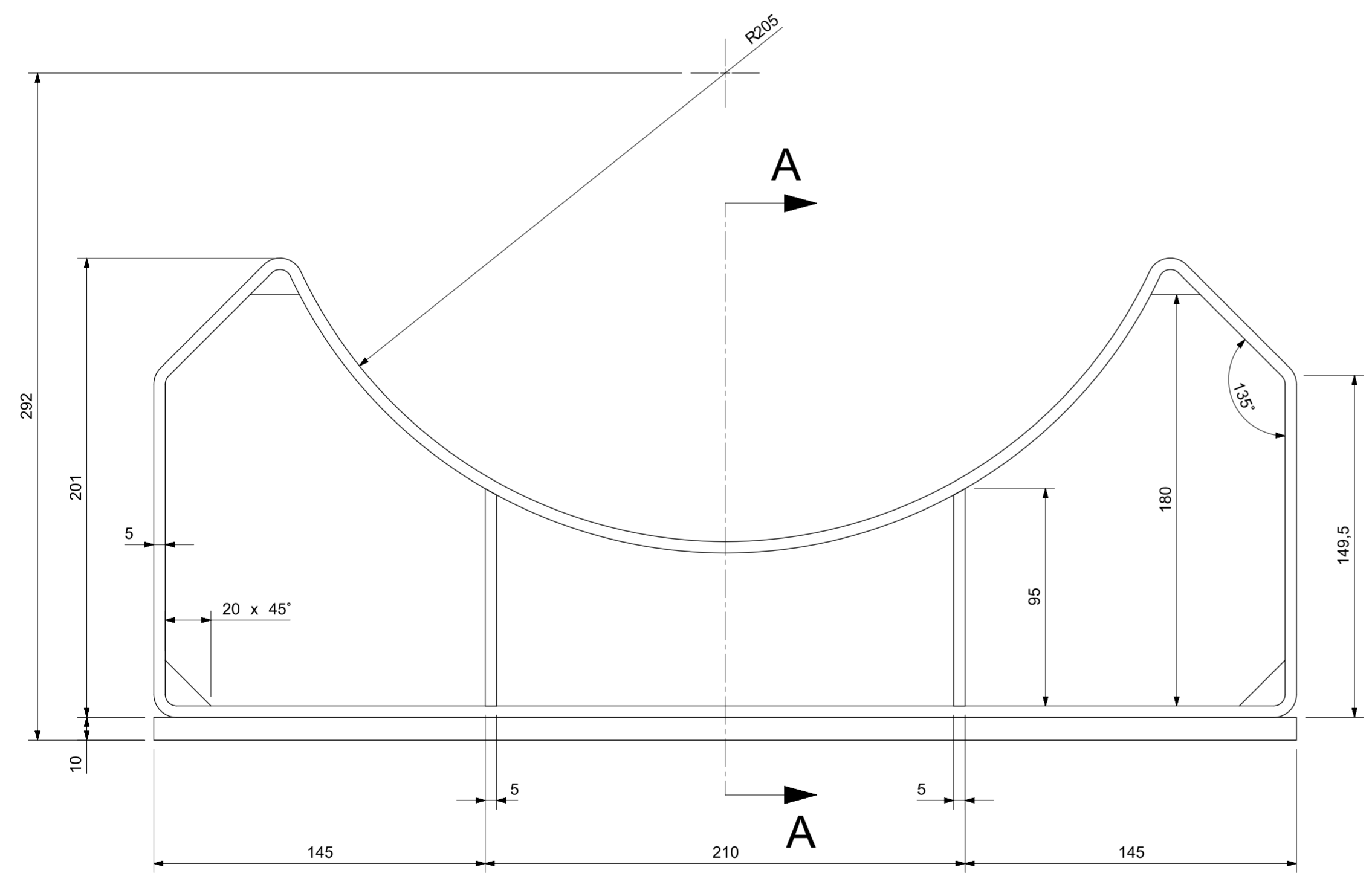

FORATURA SU ENTRAMBI I LATI

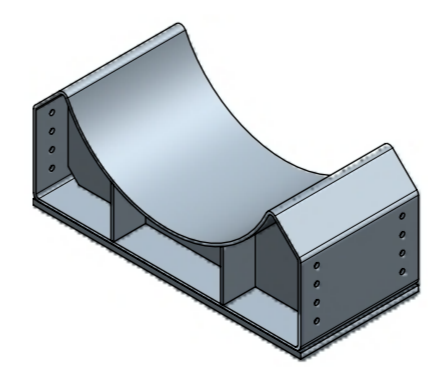
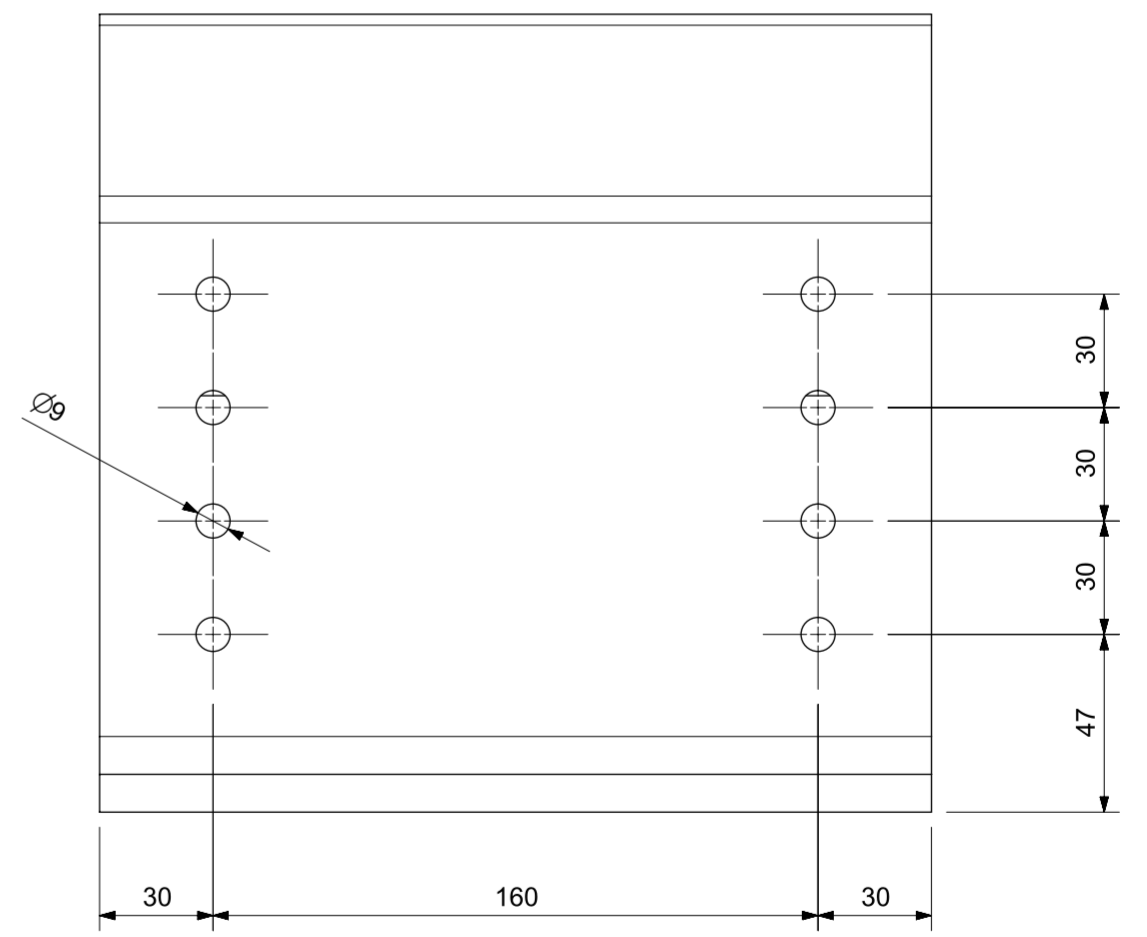

		AISI304	PIEDE SUPPORTO COMPTON	2
PART N.	DRAWING	MATERIAL	DENOMINATION	Q.TY
Gen. Tol. for untoleranced dimension: ISO 2768-mk-E		Geometrical tolerance: ISO 8015 - E		Roughness: ISO 1302
 Istituto Nazionale di Fisica Nucleare Sezione di Ferrara		Designer FEDERICO EVANGELISTI		c/o Polo Tecnico-Scientifico Blocco C - Studio 114 Via Saragat 1 - 44122 Ferrara Tel 0532974296 e-mail: evangelisti@fe.infn.it
		Approved FEDERICO EVANGELISTI		
ELI_NP		Experiment/Project		Document no. ELI_NP-COM-002
COMPTON		Scale 1:2		Date 03/12/2015
		Size A2		File name ELI_NP-COM-002.pdf
		Num. of Sheet		

All dimension in:
 mm cm m in ft

Rev.N	Revision note	Date	Signature

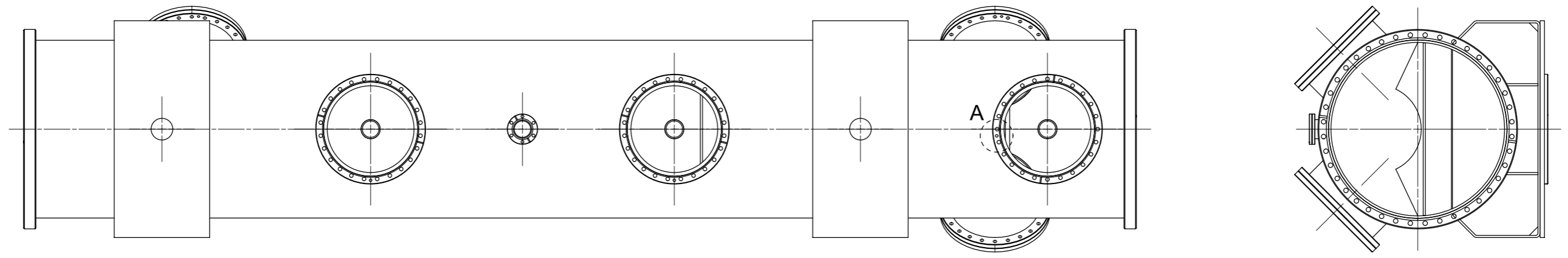

NOTE:
 - IMPORTANTISSIMO ORIENTAMENTO FORI FLANGE

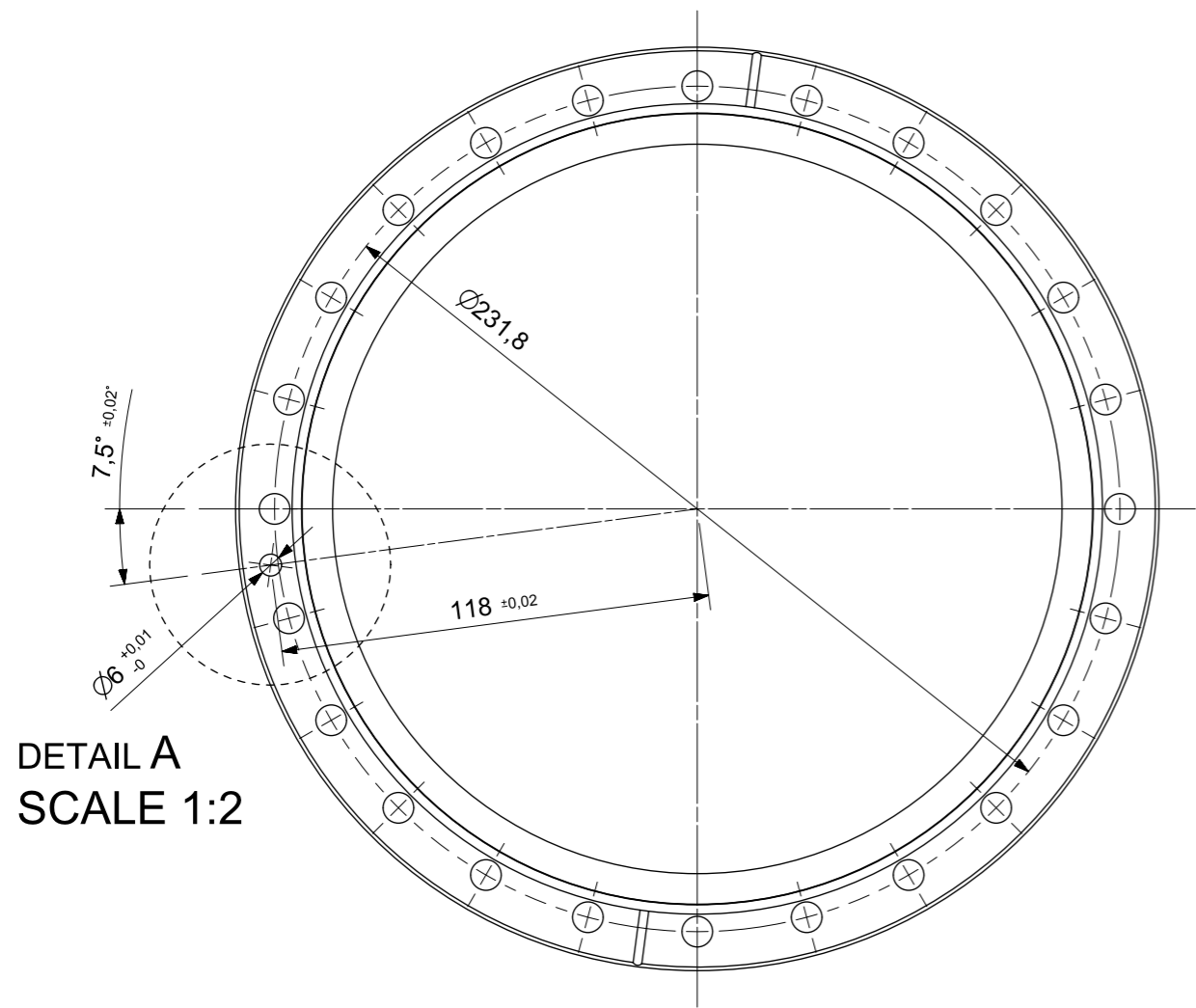

DETAIL A
 SCALE 1:2

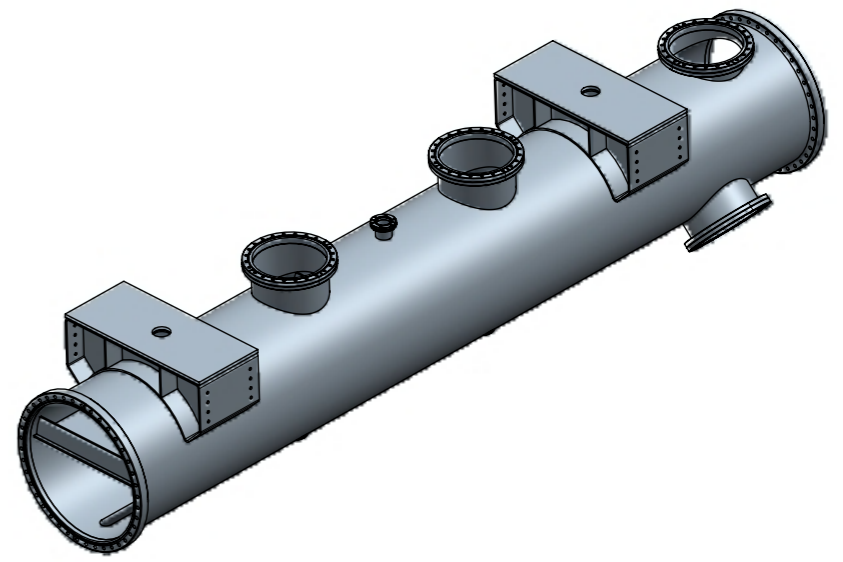

FORO SPINA CF200 HPGe			1
PART N.	DRAWING	MATERIAL	DENOMINATION
Gen. Tol. for untoleranced dimension: ISO 2768-mk-E		Geometrical tolerance: ISO 8015 - E	Roughness: ISO 1302
 Istituto Nazionale di Fisica Nucleare Sezione di Ferrara	Designer FEDERICO EVANGELISTI	c/o Polo Tecnico-Scientifico Blocco C - Studio 114 Via Saragat 1 - 44122 Ferrara Tel 0532974296 e-mail: evangelisti@fe.infn.it	
	Approved FEDERICO EVANGELISTI	Experiment/Project ELI_NP	Scale 1:10
COMPTON		Size A3	Document no. ELI_NP-COM-003
		Num. of Sheet	File name ELI_NP-COM-003.pdf

All dimension in:
 mm cm m in ft

Rev.N	Revision note	Date	Signature

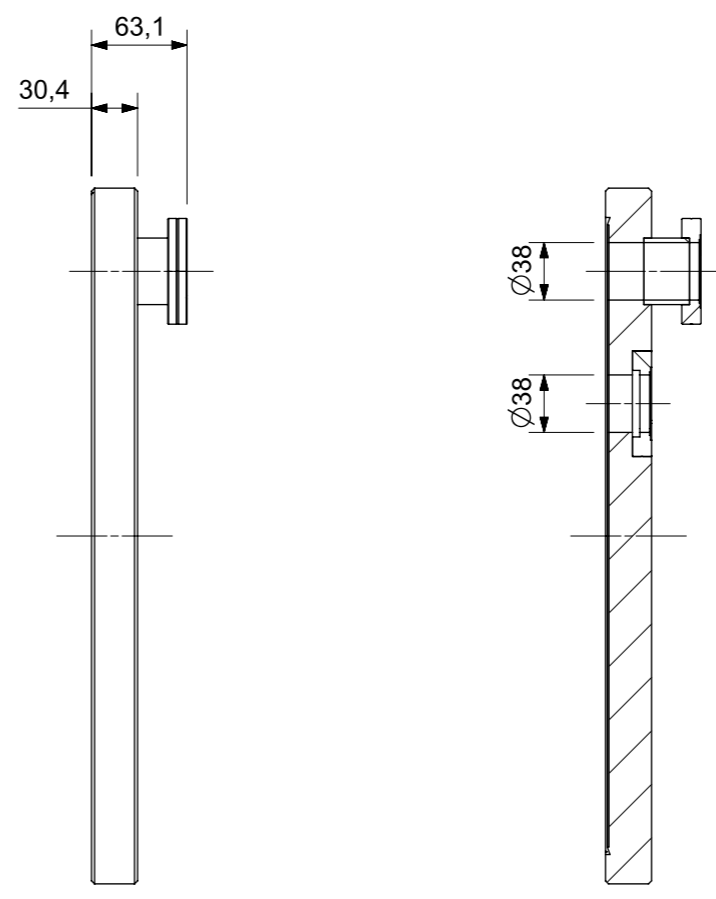
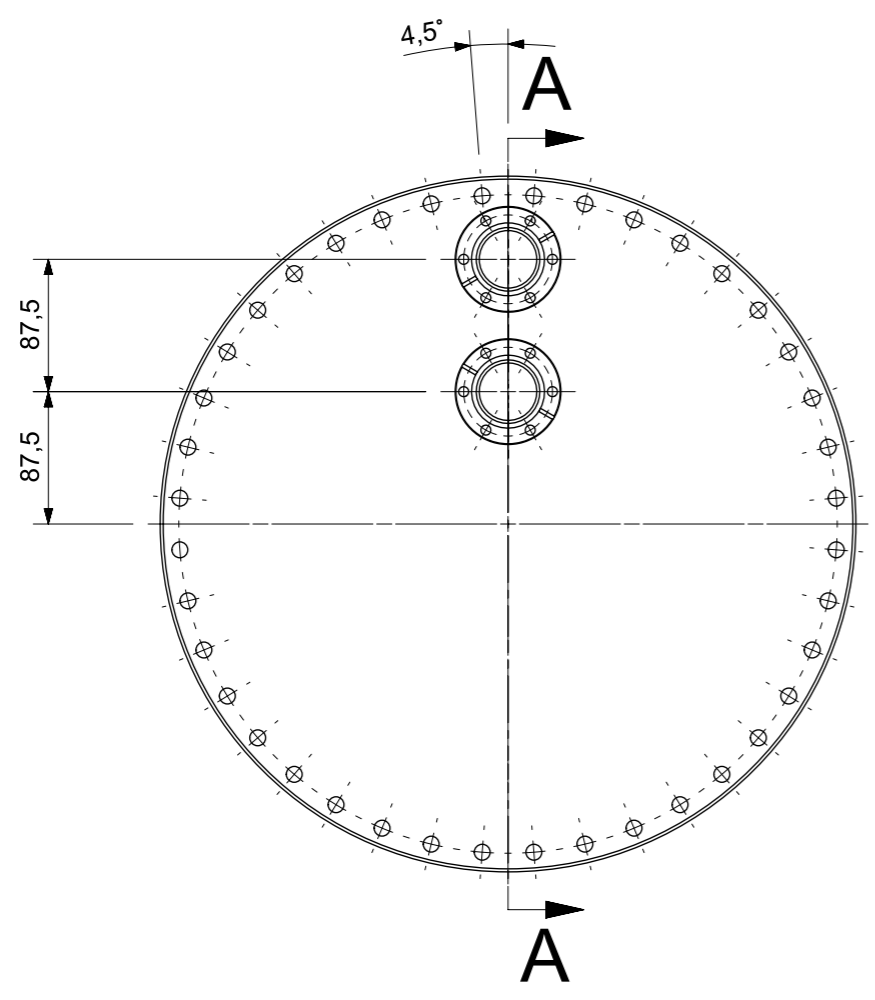

SECTION A-A

NOTE:

- FLANGIA CF400 CON FORI PASSANTI NON FILETTATI
- FLANGIA ESTERNA CF40 CON FORI PASSANTI NON FILETTATI
- FLANGIA "ANNEGATA" CF40 CON FORI PASSANTI FILETTATI
- IMPORTANTISSIMO ORIENTAMENTO FORATURA FLANGE

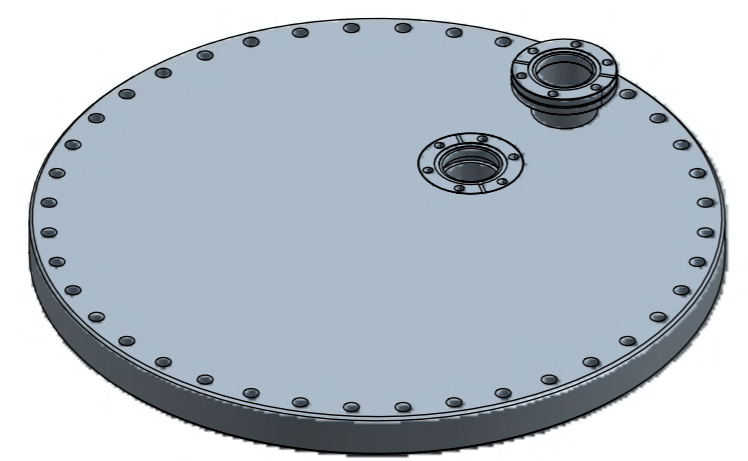

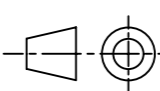
		AISI304	FLANGIA INGRESSO	1
PART N.	DRAWING	MATERIAL	DENOMINATION	Q.TY
Gen. Tol. for untoleranced dimension: ISO 2768-mk-E		Geometrical tolerance: ISO 8015 - E		Roughness: ISO 1302
 Istituto Nazionale di Fisica Nucleare Sezione di Ferrara		Designer FEDERICO EVANGELISTI	c/o Polo Tecnico-Scientifico Blocco C - Studio 114 Via Saragat 1 - 44122 Ferrara Tel 0532974296 e-mail: evangelisti@fe.infn.it	
		Approved FEDERICO EVANGELISTI		
ELI_NP		Experiment/Project	Scale 1:5	Date 041/12/2015
COMPTON			Size A3	Document no. ELI_NP-COM-004
				File name ELI_NP-COM-004.pdf

All dimension in:
 mm cm m in ft

Rev.N	Revision note	Date	Signature

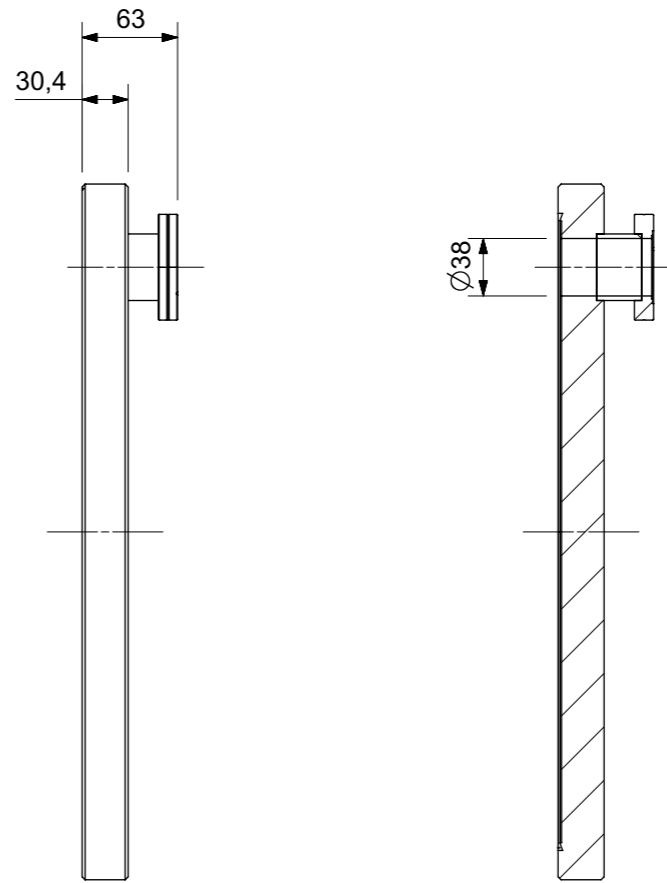
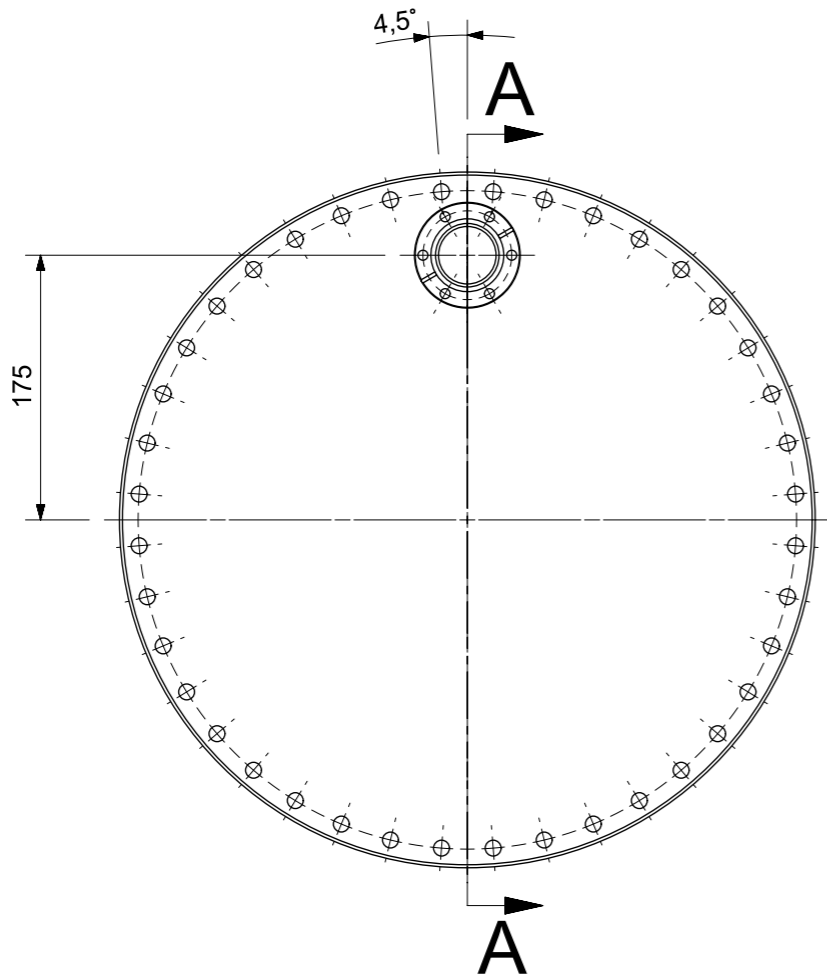

SECTION A-A

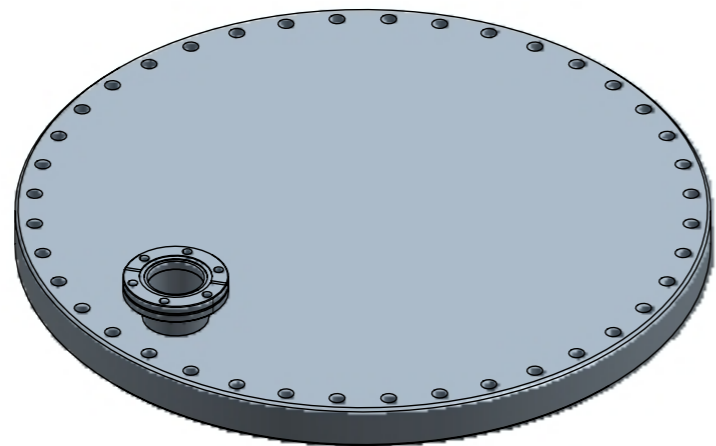

NOTE:

- FLANGIA CF400 CON FORI PASSANTI NON FILETTATI
- FLANGIA CF40 CON FORI PASSANTI NON FILETTATI
- IMPORTANTISSIMO ORIENTAMENTO FORI FLANGE

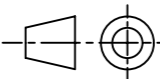
		AISI304	FLANGIA USCITA	1
PART N.	DRAWING	MATERIAL	DENOMINATION	Q.TY
Gen. Tol. for untoleranced dimension: ISO 2768-mk-E		Geometrical tolerance: ISO 8015 - E		Roughness: ISO 1302
 Istituto Nazionale di Fisica Nucleare Sezione di Ferrara		Designer FEDERICO EVANGELISTI	c/o Polo Tecnico-Scientifico Blocco C - Studio 114 Via Saragat 1 - 44122 Ferrara Tel 0532974296 e-mail: evangelisti@fe.infn.it	
		Approved FEDERICO EVANGELISTI		
ELI_NP		Experiment/Project	Scale 1:5	Date 04/12/2015
COMPTON			Size A3	Document no. ELI_NP-COM-005
				File name ELI_NP-COM-005.pdf